

Display and Controls

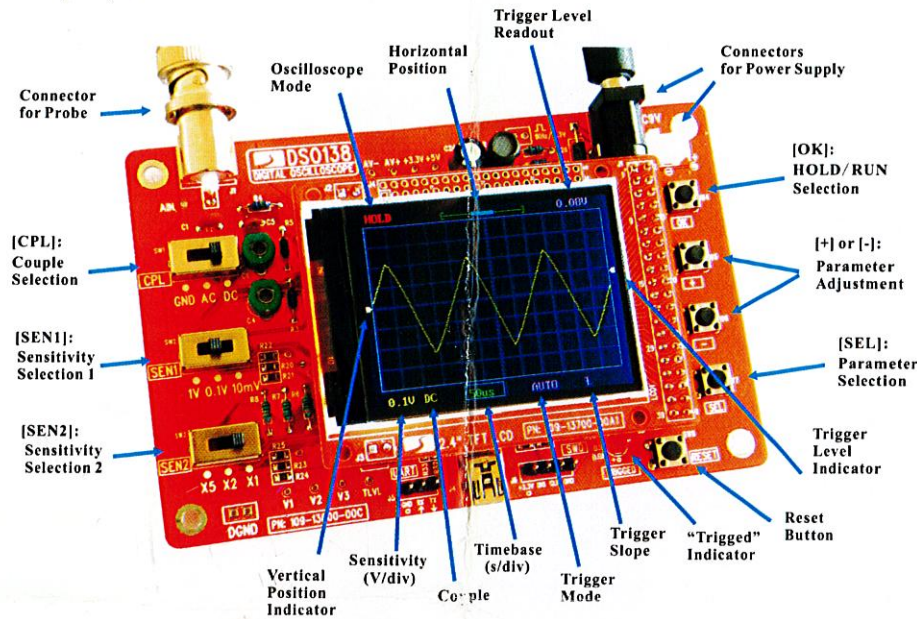

Connections

Power Supply: Connect DC power supply to J9 or J10. The power supply voltage must be in the range of 8 - 12V.

Probe: Connect probe to J1.

Attention

1. Power supply voltage must not exceed 12V. Otherwise U5 will get hot.
2. Allowed maximum signal input voltage is 50Vpk (100Vpp) with the clip probe.

Operations

Press on [SEL] button: Select parameter to be adjusted. The selected parameter will be highlighted.

Press on [+] or [-] button: Adjust the parameter selected by [SEL] button.

Press on [OK] button: Freeze waveform refresh (entering HOLD state). Press on it again will de-freeze.

Change [CPL] switch: Set couple to DC, AC, or GND. When GND is selected the scope input is isolated from input signal and connected to ground (0V input).

Change [SEN1] or [SEN2] switch: Adjust sensitivity. The product of [SEN1] and [SEN2] settings makes the actual sensitivity which is displayed at the lower-left corner of the panel.

Press on [Reset] button: Perform a system reset and re-boots the oscilloscope.

0V Line Alignment

Sometimes you may find the 0V line (the trace corresponding to 0V input voltage) does not match with the VPOS indicator at the screen left border. This can easily be fixed by performing the "0V line alignment" function. First, set the couple switch [CPL] to GND position. Then press on [SEL] button to make VPOS indicator highlighted and hold down [OK] button for about 2 seconds. You will set the trace aligned to VPOS indicator when you release [OK] button. You may see some residue mismatch remains at the highest sensitivity settings. This is normal.

Probe Calibration

Because there is always some capacitance between scope input and ground probe needs to be calibrated to achieve better measurement results for high frequency signals. This can be done with the help of the built-in test signal. To do this please follow the steps below.

1. Connect the red clip to the test signal terminal and leave the black clip un-connected (see photo at right).
2. Set [SEN1] switch to 0.1V and [SEN2] switch to X5. Set [CPL] switch to AC or DC.
3. Adjust timebase to 0.2ms. You should see waveform similar to that shown in photos below. If traces are not stable adjust trigger level (the pink triangle on right screen border) so as you get a stable display.
4. Turn C4 (capacitor trimmer) with a small screw driver so that the waveform displays sharp rightangle (photo C).
5. Set [SEN1] switch to 1V and [SEN2] switch to X1 while keep all other settings unchanged. Adjust C6 so that sharp rightangle waveform is displayed.

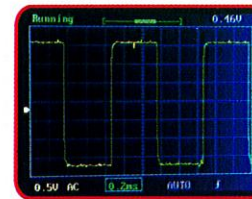
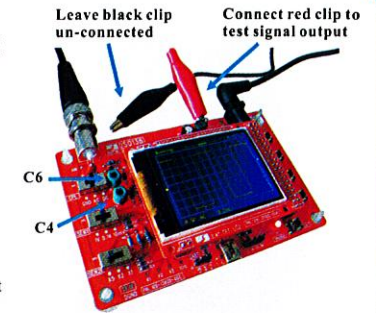

A - Not enough

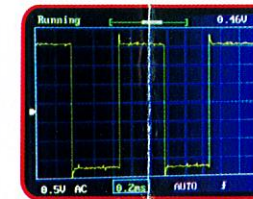

B - Too much

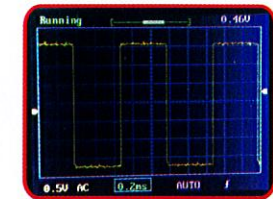

C - Good

Turn On/Off Readouts

Press [SEL] so that timebase is highlighted. Hold down [OK] button for about 2 seconds. This will turn on/off measurement readouts.

Waveform Save/Recall

Press [SEL] & [+] simultaneously: Save currently displayed waveform to non-volatile memory.
Press [SEL] & [-] simultaneously: Recall saved waveform

Triggers and Their Modes

Triggers are events that indicate signal voltage acrossing a set level (i.e. trigger level) along a specified direction (i.e. trigger slope, rising or falling). Oscilloscope uses triggers as reference points in time for stable waveform display and measurements.

Auto Mode

In auto mode oscilloscope will perform display refresh no matter triggers happen or not. When triggers are detected waveform display will be displayed with reference to trigger points. Otherwise, display waveform at random reference points.

Normal Mode

In normal mode oscilloscope will only perform display refresh when there are triggers. If no triggers happen waveform display will stay unchanged.

Single Mode

Single mode is the same as normal mode except that oscilloscope will enter HOLD state after a trigger has been detected and waveform display has been updated.

Normal and single modes are useful for capturing sparse or single waveform.

Specifications

Max realtime sample rate	1MSa/s
Analog bandwidth	0 -- 200KHz
Sensitivity range	10mV/div - 5V/div
Max input voltage	50Vpk (1X probe)
Input impedance	1M ohm/20pF
Resolution	12 bits
Record length	1024 points
Timebase range	500s/Div -- 10us/Div
Trigger modes	Auto, Normal, and Single
Trigger position range	50%
Power supply	9V DC (8 - 12V)
Current consumption	~120mA
Dimension	117 x 76 x 15mm
Weight	70 gram (without probe)

Tech Support: www.jytech.com/forum



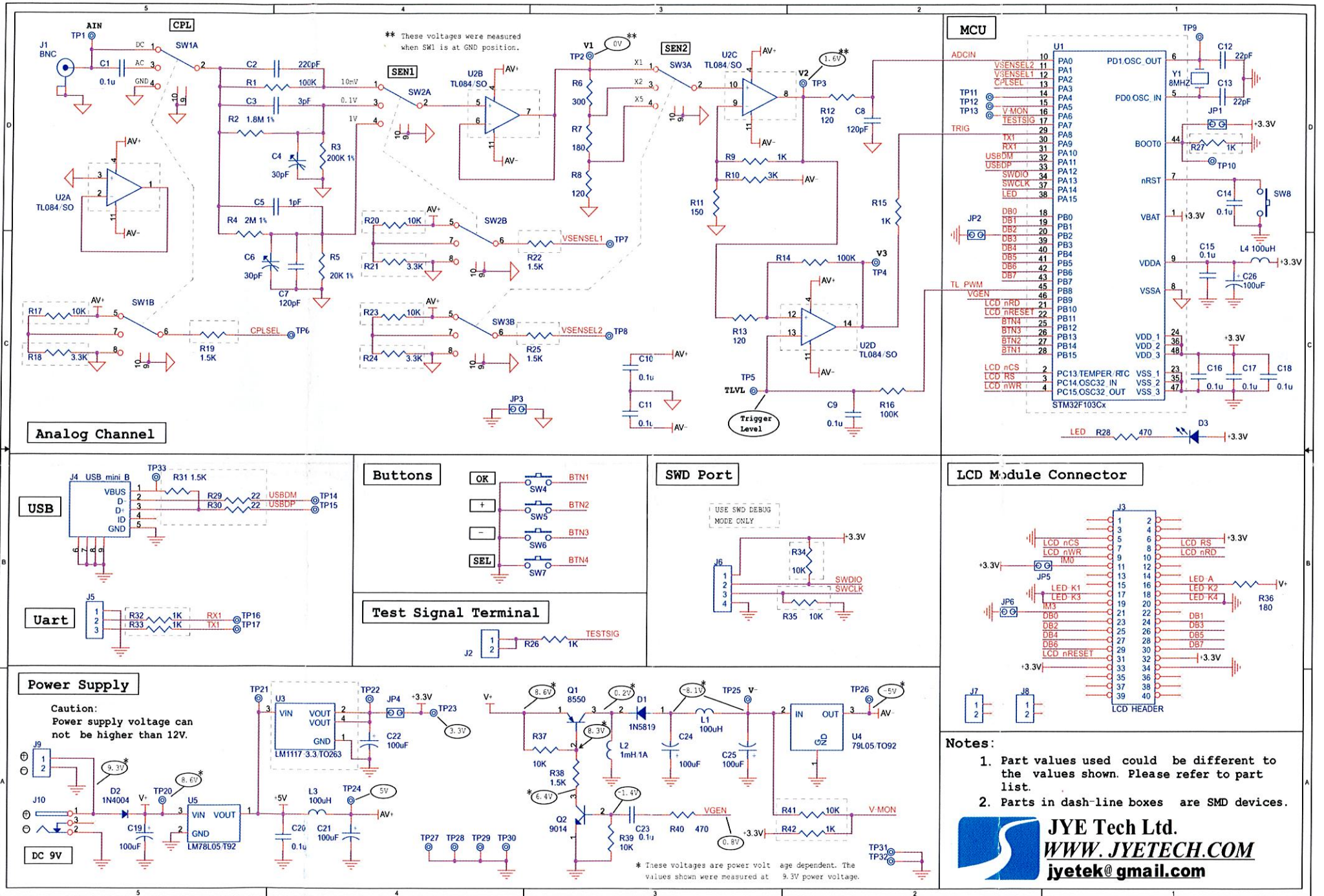

Analog Channel

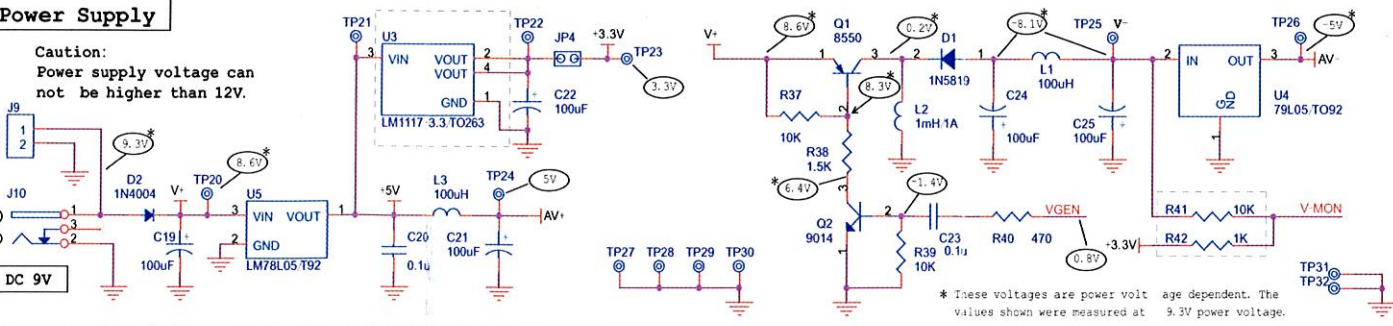
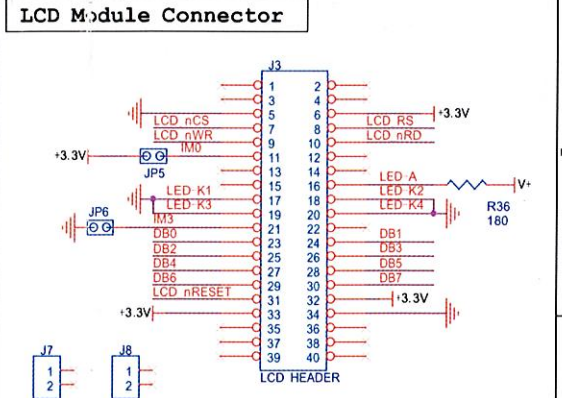
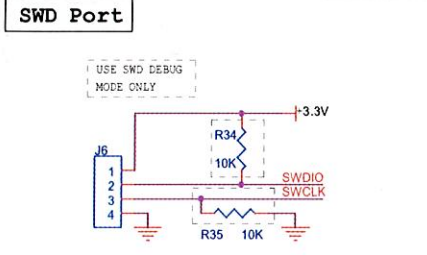
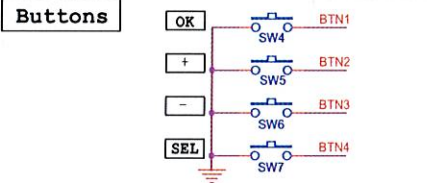
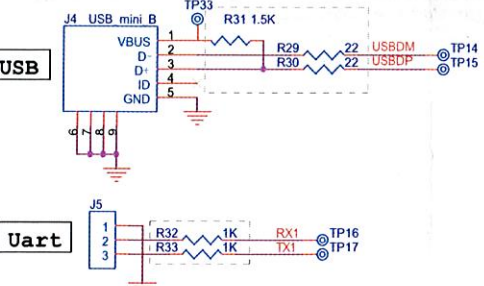

Notes:

1. Part values used could be different to the values shown. Please refer to part list.
2. Parts in dash-line boxes are SMD devices.

JYE Tech Ltd.
WWW.JYETECH.COM
jyetek@gmail.com